



## **Slide with Platform** **& Sit-down Bar** Installation Instructions

NOTES: Please check for any damage caused by the shipping company and take appropriate steps to file a claim, if needed.

\*Please call **Digsafe** and check for any underground utilities before digging anywhere.

### **Materials needed (adjust as needed)**

Cordless driver, star drive bit, selection of drill bits, carpenter's square, post hole shovel, level, tape measure, 50 lb bags of premixed concrete (not included). Concrete amounts can be easily calculated at <http://www.quikrete.com/Calculator/Main.asp>. Amount required depends on how deep you dig the holes. And obviously, you will need hardpack or road base material for under and around the slide, a plate compactor (or hand tamper) to compact this material, topsoil (or fake grass) to finish spread over the top to make it look nice, and grass seed.

If you purchased the entrance deck, it is always mounted at the top of a hill, and the underside of the slide entrance section attaches to it on the front face of the inside of the U.

These instructions assume that you have made the hill, or cut out the existing hill, so that it slopes at 35°, and that the elevational distance between the top of the hill and the bottom of the hill is accurate and takes into account the fall zone material, which has to be a minimum of 9" deep and which needs to be drained to a dry well beneath it, to daylight, or to a drainage system.

Note about the hill: All slides are sold by their "deck height." The "deck height" is the vertical drop from the top of the hill to the bottom. For this measurement, there is nothing fancy about it: it is merely the distance in feet and inches between the top of the hill where the top of the slide will be located, and the bottom of the hill where the slide bottom will be loaded. Top of hill to bottom of hill, top to bottom, highest point to lowest point. That's it.

That is your "deck height," and without fancy equipment, there is no easy way to just go out and measure this vertical drop. Read on, however, as you can get this in another way.

One crude way is by placing a STRAIGHT 2x4x8 on top of the hill, one end of which is right at the top of the slope, then lying on the top of the hill so you can sight down the top of the 2x4 with the side of your face resting on top of the 2x4, top eye closed. What you would be looking at, is a really long vertical stick placed at the bottom of the hill, and with big measurements on it (you could use a 1x3x8' piece of strapping, or two of them lapped together if your hill is higher than 8').

By sighting along the top of the 2x4 toward the vertical stick, you will see one of your foot measurements. That will give you the vertical drop of your hill!

Now — for all slides to work, the slope of the hill on which the slide rests needs to be at an ideal angle of 35°. Can this vary? Yes, to a degree.

Picture it this way: if the slope were extremely steep, like this



the kids would almost drop from top to

# Slide with Platform & Sit-down Bar Installation Instructions

bottom. That would obviously not be good.

On the other hand, if the slope were too shallow, like this the  
without pulling themselves down the slide.



kids would go nowhere

So — the optimum slope is 35°. However, you could go a little steeper, but it does mean that kids/adults would go faster, and you could go a little less steep, but it should be no less than 30°.

The best way to measure your existing slope, or to keep track of the slope as you work to change it, is to download an app (get a free one) for your smart phone called an inclinometer. Then get a nice straight (!!) 8 foot 2x4 (\$5-6) and set it on the slope at various places. This long piece of wood will even out the little ups and downs on the slope surface. Place your inclinometer on this 2x4, and voila! you'll see what your angle is.

Now you should be open to thinking about what you're doing. We say this to remind you that you **DO NOT HAVE CONTROL OVER** the actual length of your slide (it's called the run), because the length of the **RUN** is determined by the vertical drop and the slope. It's the classic right triangle, the old Pythagorean Theorem: In algebraic terms,  $a^2 + b^2 = c^2$  where **c** is the hypotenuse while **a** and **b** are the legs of the triangle, where "b" is the vertical drop of your hill (top to bottom), and the angle between "a" and "c" is the ideal 35°.

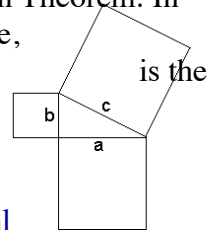

If you have "b" measured right, and your slope set right, then "c" is an automatic given length. To help even further, here's a helpful link: <http://www.csgnetwork.com/righttricalc.html>

Now, if your slope is already at 35° or you're making a slope that is 35° (or some other angle close to it), and you measure the run of the slope "c" to be a certain length, then you can easily calculate where on the slope you need to place the start of your slide.

Then you can order from us either way: you can say I want to order a slide with a deck height of X (the "b" in the image), or you can say that I want to order a slide that has a run of Y (the "c" in the image), and we'll figure out what the deck height should be.

**NOTE: Embankment slides are meant to be supported by the earth. For many reasons, including aesthetics and safety, embankment slides should be embedded into a shallow, curved swale carved into the surface of a hill. This swale should be 11 inches deep at its center, and should be approximately 18 inches across, lip to lip, like so:**

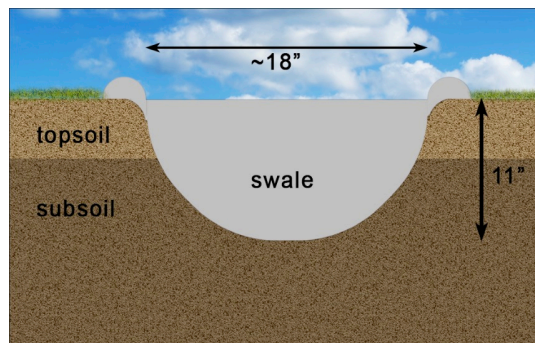

# Slide with Platform & Sit-down Bar Installation Instructions

**This ensures that the slide has support all the way down, that kids can't climb up onto the side rails and fall to the ground, and it ensures that the slide platform, the slide crib stair, and slide fall zone kit all fit together perfectly and give you the right safety clearances.**

**Ensure the hill swale in which the slide sits is at 35°, and that it is deep enough so that the slide rails rest on the ground, or close to it. You must make sure that the material under the entire length of the slide is fashioned/shaped and compacted so the slide rests on this material its entire length.**

## **To Install Slides up to 6' deck height**

1. The fall zone at the bottom of the slide is mandatory, so start by preparing the fall zone area. If you are sitting on the bottom of the slide, the fall zone must extend 6 feet to the right of the slide, 6 feet to the left of the slide, and 6 feet out in front of the slide lip. For slides taller than 6 feet, the fall zone has to be at least 2 feet wide and extend 8 feet out in front of the slide lip. If you purchased our slide fall zone kit, it will be the perfect size and is designed to be an integral part of the installation package. See those separate instructions.
2. Move individual pieces near desired installation location at or near the top of the hill.
3. All slides are required to have an entrance platform. If you purchase this from us: Remove the deck boards that will allow you access to the front joist under the deck to which the underside of the slide entrance section is fastened, and to which the posts for the site-down bar are attached. Not all deck boards have to be removed unless you choose to install footings under the corners of the platform.
4. Find the sit-down bar and 2 posts, assemble it, and place it on the frame of the deck where the holes have been cut out. The logo should be facing to the uphill side (away from the slide). The bottoms of the posts should be flush with the bottom of the joists.
5. NOTE about the entrance deck: it is meant to be buried so that the platform is flush with the grade at the top of the hill. This is enough to permanently anchor it into place. However, if you have to elevate the deck slightly to accommodate fine adjustments, you may want to anchor the deck to footings, in which case there is a footing diagram attached below.
6. Once the deck is set as desired, and the sit-down posts (and, if you ordered the crib stair, the rope rail post: see below) have been mounted, *temporarily* replace the deck boards to fill the hole. You still need to fasten the slide to the front inside of the deck's U.



# **Slide with Platform**

## **& Sit-down Bar**

### Installation Instructions

7. If you also purchased a crib stair, it comes with a rail post at the top, which is installed in the same way. If for some reason the hole for this crib stair was cut out on the wrong side (our mistake !! :( you may be able to flip the board with the cutout to the other side, or you might have to cut out another hole for the post.
8. Fasten the small pieces of decking with the rounded, finished edge to the very front edges of the deck on both sides of the slide opening. These boards are meant to overhang the front so that dirt, rocks, and/or the crib stair go up right underneath them to provide a “smooth” transition.
9. Complete slide installation:
  - Ensure the hill swale in which the slide sits is at 35°, and that it is deep enough so that the slide rails rest on the ground, or close to it. You must make sure that the material under the entire length of the slide is fashioned/shaped and compacted so the slide rests on this material its entire length.
  - If you have a long slide, you may have automatically received one or more middle support posts. See the following section for installing longer slides.
  - If your slide comes to you NOT totally preassembled, then assemble the whole thing into one unit (unless, of course, you have a super long slide, or your slide has left and right turns in it). See the following section.
  - Temporarily lay the slide in the swale and make necessary adjustments to the hill
  - The wooden slide mounting plate should be attached to the slide when you receive the slide. If it's not, attach it.
  - Keep the measurement from the top of the exit seating area to the top of the fall zone in mind when locating the footing under the foot. For toddler slides, it's 6", for up to 4' high slides, it's 11", and for slides over 4' high, it's 15".
  - Dig the slide foot post hole (12" diameter preferable) approximately 3'-6" deep (depending on region), and insert a sonotube into the hole. Where applicable, the bottom of hole should “flare” out a little to create a bell shape to prevent frost heaving the post.
  - Flip the slide over on its side and attach the metal support to the bottom of the slide foot. All slides, regardless of length, come with this foot support, which is a 2 inch diameter pipe approximately 4 feet long, at the top of which is a flat plate with holes in each corner. (see discussion above) You'll need to flip the slide over so you can fasten this plate/pipe under the slide foot (which is under the exit region of the slide). This pipe is put into a concrete footing to anchor the bottom of the slide, which prevents it from moving down the hill. You can cut this pipe to a workable length as long as it is anchored into the concrete.

# Slide with Platform & Sit-down Bar Installation Instructions

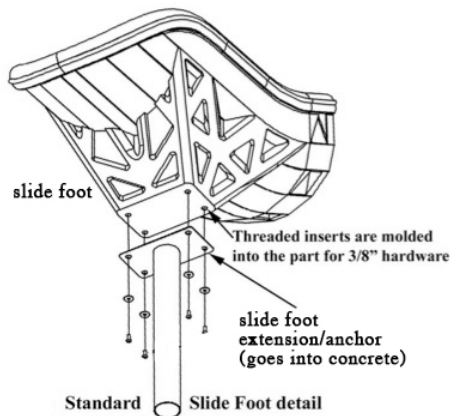

- Determine the height of the metal support to provide the correct drop distance from the slide seat to the top of the fall zone material (see above).
  - Flip the slide over to right-side-up, metal post in the hole, and rest the lip on the underside of the entrance section on the inside front of the platform U, then adjust the bottom to the correct height off the fall zone material, and set up a temporary support/stop to keep the bottom at that height when you pour the concrete and set the metal support into it. This temporary support **MUST** stay in place until after the foot concrete is poured and cured. The support can be put between the ground and the underside of the rails at any point that works, or you could build a short crib between the very front lip of the slide and the ground, or, or... This has to be jerry rigged, as there is no one way to do this, but the next step requires you to lift the slide out of the way to pour the concrete, and then put the slide back so it rests on this temp support, so make sure the temp support can stay where you want/need it.
  - Lift the slide and its foot post up and out of the way so you can pour the concrete (you'll need a few people to do this, as the post is long and awkward to lift up and out of the hole).
  - Pour the concrete, then flip the slide so it's upright. Position the slide in the right place by making sure the top/entrance section of the slide will fit where you want it on the front edge of the deck, and the pipe at the bottom is going into the concrete where you want it, then push the metal support pole into the concrete until it sits on the temporary stop.
  - Remove those few deck boards once again, and fasten the slide deck plate to the deck. There should be pre-drilled holes through the header/joist to which the wooden slide "plate" is fastened (see image above). Use the enclosed GRK screw fasteners to fasten these two together, then permanently attach the deck boards.
  - Backfill with road base material around the sides of the slide (remember to allow for topsoil or for the fake grass structure), and compact as you go.
  - We do have profiles of the slide installation for the various height slides, so don't hesitate to ask for them.
8. Make sure the fall zone is laid out properly. If you are using our fall zone kit, follow instructions. For slides with a deck height of 3 feet, the fall zone must extend to a semicircular distance 3 feet out from the 2 front

# Slide with Platform & Sit-down Bar Installation Instructions

corners at the end of the slide. This means the back retainer that goes under the slide will be 8 feet in total length. For slides with deck heights up to 7 feet, that same fall zone has to extend in a 6' semicircle from each of the bottom corners of the slide (that back retainer will be 14' total length). For slides over 8 feet, you may use the same 6 foot fall zone size, except directly in front of the slide, it needs to extend away from the end of the slide an additional 2 feet, for a total of 8 feet.

9. SIDE NOTES: About the fall zone retainer
  - a. The fall zone retainer hole needs to be at a minimum depth of 9". This is a hole, and it needs to be drained. If you go to 12" deep, there is room for a 4" perforated drain. Alternatively, you could make a deep dry well under the fall zone material, topped with heavy duty landscape cloth. Keep in mind that there is a fairly large hill draining into this fall zone, so plan the drainage accordingly.
  - b. The top of NPC 6x6 retainers are essentially flush with the ground (see red note on right of image) — except for the back one (see left red block), which is higher because it needs to contain the earth/stones/crib stair behind it. This retainer can either rest on an earth shelf, or it could go down to the bottom of the fall zone. Because it goes under the slide, it will be broken by the slide foot and slide anchoring post.
10. Add loam to be flush with platform and fall zone retainers, and sod or seed for grass.
11. Add fall zone material to the correct height.
12. All wood is treated with kid-friendly preservative, but as is the case with all wood facing the elements, it needs to be cared for, so check it periodically for rough spots, splinters, etc, sand them out, and treat again with kid-friendly wood preservative we sell in our store for best results

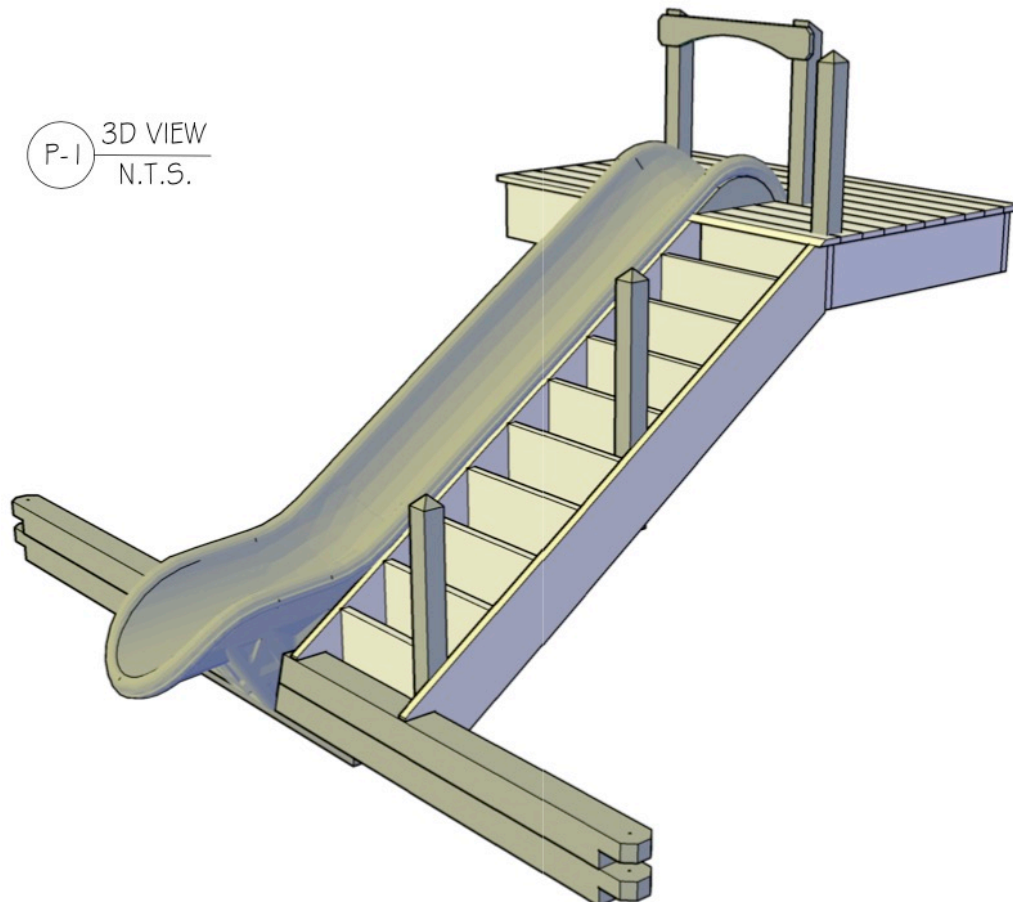

# Slide with Platform & Sit-down Bar

## Installation Instructions

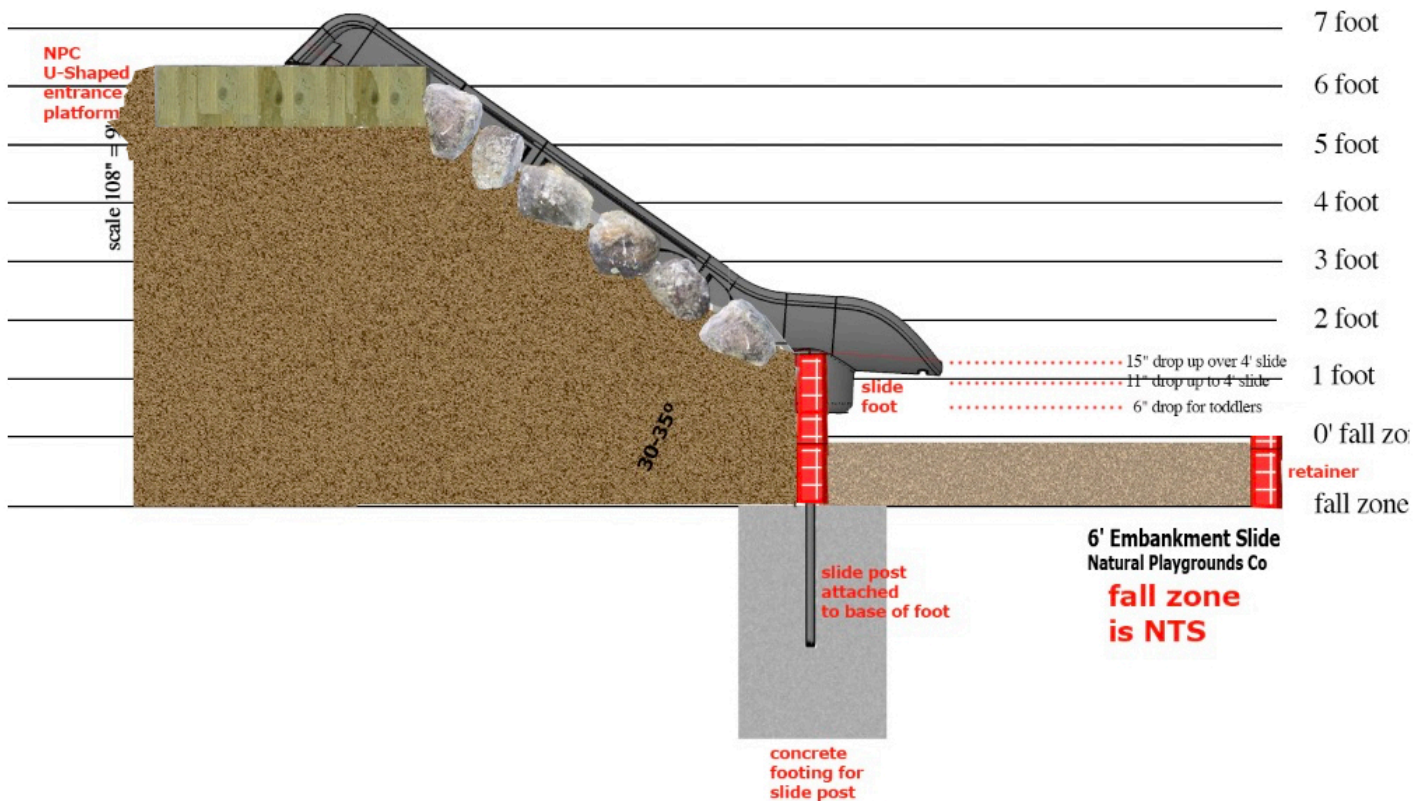
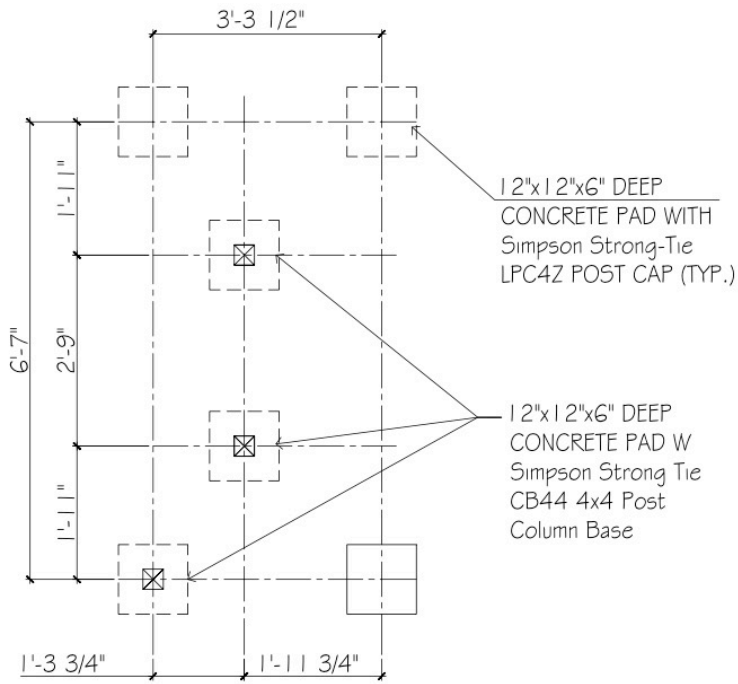

# Slide with Platform & Sit-down Bar

Installation Instructions

13. Re-treat once or twice a year to keep the wood from deteriorating.

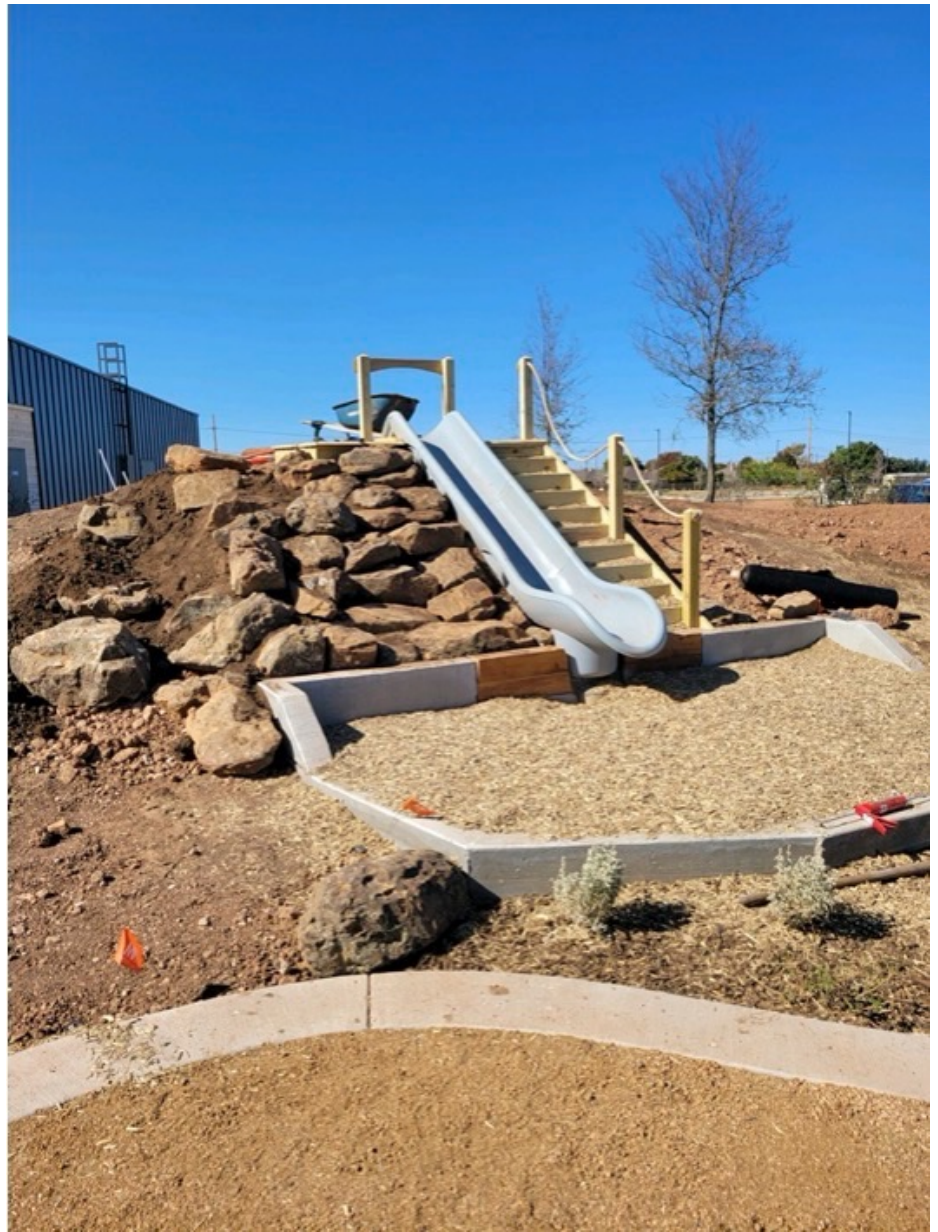



# **Slide with Platform** **& Sit-down Bar** Installation Instructions

## **To Install Slides 7' deck height and higher**

The reason this is a separate section, is that are other considerations when installing higher/longer slides, so we need you to think this through before starting.

You may come up with different or even better ideas, but at least you'll know what you're dealing with.

So - first, is that we recommend using mid supports for longer slides. We send these with the slides, and it is your choice whether to use them, but we do recommend them. Here's why: longer slides are obviously heavier, so gravity is always inviting them to slide down the hill. Obviously, they'll be locked in with earth around them, so the likelihood of them sliding down on their own is pretty slim indeed.

But add the weight of heavy people, or maybe even more than one heavy person at a time, and now there is more weight for gravity to pull down, and some of that pull will be transferred to the slide by friction of clothes against the slide. Friction against the slide is trying to pull the slide along with the moving person.

Throw into the mix some really wet soil after a long winter melt, or heavy rains, and now the slide may be even more susceptible to traveling downhill ever so slightly.

All this can be prevented by using mid supports along the length of the slide run.

Shorter slides come preassembled, so all you do is take them off the truck, carry them to where you want, prepare the hill, prepare the footing, and prepare the entrance platform, and you are good to go (if you follow the above instructions).

However, longer run slides will come in two sections or more. Again, you can carry each of the sections to the site, flip them over upside down, put them together, then flip the whole slide back over again and put it into place.

Obviously, because of the weight of the slide, there is a limit to how long the slide is before it is way too heavy to flip over.

All slides, regardless of length, come with a foot support, which is a 2 inch diameter pipe approximately 4 feet long, at the top of which is a flat plate with holes in each corner. (see discussion above) You'll need to flip the slide over so you can fasten this plate/pipe under the slide foot (which is under the exit region of the slide). This pipe is put into a concrete footing to anchor the bottom of the slide, which prevents it from moving down the hill. You can cut this pipe to a workable length as long as it is anchored into the concrete.

Now you can see the issue. This 4 foot long pipe is sticking up in the air, which now makes flipping the slide over to right side up difficult. You could hold it high in the air, and then flip it over, and then drop it and the pipe into the footing hole (that you are later going to fill with concrete). It would certainly work, but it would take several people with strength, and a lot of preplanning.

Obviously, with longer slides, this mid air flip will be extremely difficult, or impossible.

# Slide with Platform & Sit-down Bar Installation Instructions

It will be even more difficult if you have two or three mid supports also sticking up in the air 4 feet. There will come a point, where no matter how many people you have standing on that 35° slope lifting this slide high in the air, then flipping it over, and then gently lowering it onto the ground, trying to get those pipes going into the holes you've dug, that this whole scenario won't be possible.

NOTE about the mid-support. As described above, it is a 2 inch diameter pipe about 4 feet long, at the top of which is a cradle for a slide section joint. It is attached to the underside of the slide sections using the bolts and nuts in that joint. Essentially, the cradle is sandwiched between two sections of the slide. The mid-supports can be cut to any length, but they should be long enough to be able to be embedded in concrete.

## Step-by-step to install long slides

For any slide that is going to require a mid support, the whole slide will be installed in sections, the first of which will be the bottom section of the slide, from the exit region and foot up to the area of the first mid support.

1. Find the mid-support pipe(s) with cradle and two straight sections. Depending on how the slide came to you, you may have to disassemble part of the slide to attach the mid support to it. Fasten the mid support to the chosen joint.

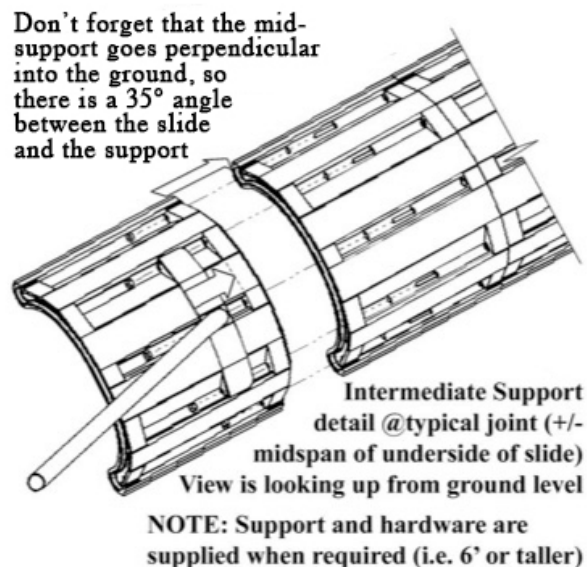

2. After you've dug the hole for the slide exit footing pipe, flip the bottom/assembled portion of the slide over and set it into place as close to the final point as possible.
3. Use orange paint or some other marker to mark the top end of the slide. You will be digging a shallow trench at this point, perpendicular to the slide run so you can reach under the slide to insert the bolts and the nuts that fasten the sections together.
4. Take the two section piece with the mid support pipe attached to it, place it upside down at the top/uphill end of the first slide section so you can see where the hole for the footing has to be dug. Mark that spot.

## **Slide with Platform** **& Sit-down Bar** Installation Instructions

5. Also mark the spot at the top of that two section piece with the mid-support pipe, because you will also need to dig a shallow trench perpendicular to the run of the slide at this point, and every other point going up where you need to join the sections together. These small, shallow trenches allow you to reach underneath to insert the bolts, nuts, and wrench to tighten everything.
6. Remove the slide pieces, dig your perpendicular trenches and dig the hole for the pipe. If you are using a sonotube, insert it into the hole so the top is flush with the bottom of the swale.
7. At this point, you can go ahead and install the lower section of the slide as discussed in other parts of this installation guideline.
8. When the footing concrete has set, you are ready to install the two sections with the mid-support post attached by first pouring concrete into the sonotube, then pushing the mid-support post into the concrete while lining up the holes for the bolts and nuts.
9. Attach this small section to the rest of the slide. Make sure to tighten the nuts.
10. You can now proceed installing the other sections of the slide in the same manner as above.
11. When you reach the top of the hill, and are ready to install the last portion with the entrance section that attaches to the platform, go back to the above discussion for proper installation instructions of the platform and its attachment to the slide.

